

Introduction

The ShockLog[®] 298 combines advanced tri-axial piezoelectric accelerometer technology with sophisticated electronics and software to offer an advanced shock and vibration data logger. The comprehensive Windows[™]-based software allows the wake-up, warning, and alarm levels, frequency of data collection, settings of the acceleration range and frequency cutoff filters to be set by the user. When a programmed impact level is exceeded, a detailed event curve will be recorded and a visual alarm will occur alerting the user to the fact that damage may have occurred.

FEATURES
Records impact events; max peaks X, Y, and Z; gRMS; and internal temperature
Field-proven tri-axial piezoelectric accelerometer technology
User-definable warning and alarm levels
LED lights for visual notification of alarms and warnings

Contents

ShockLog [®] 298 Key Features	2
ShockLog [®] 298 Specifications	3
Factory Fit Specifications	5
Accessory Specifications	6
Product Construction	7
How to Use the ShockLog [®] 298	7
Communications.....	7
Security	8
Software.....	9
Product Selection	10
Best Practices for Mounting.....	11
Drawings.....	12
Accessories & Related Products	14
Declaration of Conformity	14
Ordering Information.....	15
Technical Support	16
Warranty	16
Limitation of Liability.....	17

ShockLog[®] 298 Key Features

The ShockLog[®] 298 has been designed to monitor shock and vibration based on acceleration or velocity measurements. It has several unique features, which make it especially suitable for applications where the cost of exposure to out-of-specification environmental influences is very high. The instrument is equally suitable for protecting high-value fixed or mobile installations and investigating shock and vibration during transportation.

The ShockLog[®] 298 has 12 user-selectable ranges:

- Acceleration in G 1.0, 3.0, 10, 30, 100 & 200
- Velocity in cm/s 1.0, 3.0, 10, 30, 100 & 200

Selectable hardware filters allow users to limit the response of the unit to a select frequency range. The frequency filter range covers from 10Hz to 250Hz.

When any of the accelerometer signals or the external input exceeds the 'wake-up' threshold, the processor turn on and check the sensor outputs at full sampling speed (4096 samples per second per axis). If the output of any sensor exceeds the warning or alarm thresholds, the ShockLog[®] 298 will record a detailed event and flash its status LED accordingly. The ShockLog[®] 298 series offers a "traffic light" system to inform the recipient of the potential magnitude of any given impact utilizing the following sequence:

Green = No Alarms
Amber = Warning
Red = Alarm

In addition, the detailed time history of the first event to set a warning, the first to set an alarm and subsequent events up to the installed memory capacity will be recorded, which depending on setup, could be up to 870 Events. The ShockLog[®] 298 will adjust the recorded sample rate during the event recording (within parameters set by the user) to make the most efficient use of memory and capture the full extent of any events.

The ShockLog[®] 298 also supports peak recording in fixed time slots. In this mode the highest and lowest signal level present on each input is recorded for each time slot. The time slot length may be set between 10 seconds and 1 hour, and as many as 51840 slots, (peak x, y, z and temperature), may be recorded. The slots may also include data from optional sensors.

User-Selectable Time Slot Data:

- Max Peaks X,Y,Z 3 bytes
- Min Peaks / gRMS / Ext {X,Y,Z} 3 bytes
- Ext1 or Tilt & Roll 2/4 bytes
- Internal Temperature 2 bytes
- Options
 - Humidity 2 bytes
 - Pressure 2 bytes
 - External Temperature or Dew Point 2 bytes

A feature of the ShockLog[®] 298 is the ability to set alarm conditions on any of the selected slot data; most parameters have a high and low alarm setting point. These alarm status alerts will be signaled to the

recipient via a different LED to the Event Alarm, with Green showing an all clear status and Red warning of a slot alarm breach.

In addition to events and time slots, the device checks the output of the sensors (the three built in accelerometers, the built in temperature sensor and any external sensors) once every 10 seconds. The information from the sensors is merged into a summary record for each recording period and recorded in nonvolatile memory. The length of the summary period can be set between 10 minutes and 24 hours and there is sufficient memory for 1024 periods.

The ShockLog® 298 series has the option to set the Slot information as gRMS records providing users with the ongoing vibration levels being seen throughout a journey or during a product's life.

ShockLog® 298 Specifications

Complete Instrument	
Operating Temperature Range	-40 to 85°C / -40 to 185°F
Drop Test Survival	1m / 39.4in
Dimensions (over connectors & humidity chimney)	123 x 78 x 55mm / 4.8 x 3.1 x 2.2in
Weight (without Battery)	515g / 1.14lbs
Battery	2 x 3.6V Lithium Thionyl Chloride 2 x 1.5V Alkaline Size AA
Battery Life	Up to 18 months w/ Lithium battery
Case Material	Aluminum
Sealing	IP67
Accelerometers	Piezo
Software	Functions on Windows XP, Vista, 7, 8
Communications / Interfaces	
USB 2 Compliant 12Mbps – effective baud rate	256k
RS232 levels, Rx and Tx Baud rates	19200 (Rx) 57600 (Tx)
iButton	
Optional RF Radio Link	IEEE 802.15.4
Indicators	LEDs - 2 Bi-color and 1 Red
A-D Converter Resolution	12 bits
Flash Memory for Data	4096kbytes
External Power Source Option	6 - 30V
External Power Source Average Current (normal)	3.5mA (Typ)
External Power Source Average Current (clearing or downloading)	50 (TBC) mA
External Power Source Start-up Current	500 (TBC) mA

EMC

ETSI EN 301 489-17 v1.3.2 (2008-04)
 ETSI EN 301 489-1 v1.8.1 (2008-04)
 EN61326-2-1:2006
 EN301489-17-V2.1.1
 FCC RULES CFR47: PARTS 15.107 & 15.109
 RTCA DO-160F-Section Radiated Emissions Category B

Data Collection

Event Processor Wake-up Delay	2.5ms
Timeslot Interval	10 to 3600 seconds
Samples per Channel per Event	512 to 4096
Maximum Number of Events (detailed)	108 to 870
Event Duration	1 to 128 seconds
Number of Timeslots (depends on slot contents)	14608 to 467456
Maximum Number of Summaries	1024

Accelerometers

Low Frequency Cutoff (-3dB 10g – 100g)	0.1 - 0.5Hz
High Frequency Cutoff (-3dB)	250 – 300Hz
Hardware Filters (Programmable)	10Hz, 40Hz, 50Hz, 90Hz, 120Hz and 250Hz
Resolution (% of full scale) 1% for Peaks	0.1%
Scale Factor Accuracy at 5G (event record)	±2%
Additional Error Other Ranges	±2%
Additional Error Peak Capture	±5%
Change of Scale Factor over Temperature	±4%
Acceleration Ranges	±1 to ±200G
Velocity Ranges	±1 to ±200cm/s
Wake-up Threshold (% of range)	5 to 95%
Warning and Alarm Thresholds (% of range)	5 to 95%

External Analog Sensor Input

Input Voltage Range	0 to 4.5V
Low Frequency Cutoff	0 Hz
High Frequency Cutoff (-3dB)	200 to 280Hz
Resolution	2mV
Scale Factor Accuracy at 4V	±2%
Change of Scale Factor over Temperature	±2%

Factory Fit Specifications

Humidity / Temperature Specifications	
Temperature Measuring Range	-40 to 85°C / -40 to 185°F
Temperature Accuracy	±2°C / ±4°F
Temperature Resolution	0.1°C
Humidity Measuring Range	0 - 100% RH
Humidity Accuracy	±3% RH
Humidity Resolution	0.1% RH
Dew Point Measuring Range	-40°C to 85°C / -40°F to 185°F
Dew Point Relative Accuracy (-20 to 70°C, 25 to 75%RH)	0 - 100% RH ±2°C / ±4°F
Dew Point Resolution	0.1°C

Radio Link	
Indoor/Urban Range	up to 100m
Outdoor Line-of-Sight Range	up to 1500m
Transmit Power Output	10mW (10dBm)
Operating Frequency	2.4 GHz
Receiver Sensitivity (Per 1%)	Up to -100dBm
RF Data Rate	250,000 bps
Packet Data Rate	Up to 125k baud
Network Topology	Point-to-Multipoint

RF Base Specifications	
Radio	ZigBee Module
Power Levels	10mW (10dB)
Data Transmission Rates	115,200 baud

Tilt & Roll Specifications	
Tilt Range Monitored	±180°
Resolution	0.1°
Transverse Sensitivity	5%

GPS Specifications	
Sensitivity	157 dBm reacquisition 148 dBm cold starting
Fast TTFF	1s/29s (hot/cold start)
Channels	65
Hypothesis Testing per Second	8,000,000 time-frequency
High Accuracy Position	2.5 CEP Velocity 0.1m/sec

Accessory Specifications

External Temperature, Humidity, and Pressure Sensor	
Temperature Measuring Range	-40 to 85°C / -40 to 185°F
Temperature Accuracy	±2°C / ±4°F (1 bar unit) ±4°C / ±8°F (2 bar unit)
Humidity Measuring Range	0 - 100% RH
Humidity Accuracy	±3% RH (1 bar unit) ±6% RH (2 bar unit)
Pressure Measuring Range	0 - 1.1 bar (standard) 0 - 1.2 bar (optional)
Pressure Accuracy	±10% mbar (1 bar unit) ±60% mbar (2 bar unit)
eTrak GPS/GPRS	
Operating Temperature Range	-40 to 85°C / -40 to 185°F
Dimensions	160 x 250 x 40mm / 6.3 x 9.8 x 1.6in
Weight	696g / 1.53lbs
Regions	Globally provided GSM network coverage available

Product Construction

The ShockLog® 298 has been designed to function reliably in difficult environments. The electronic components are assembled using surface mount technology. The complete electronic assembly is coated with acrylic resin and enclosed in the aluminum case. The securing bolts pass through the body of the instrument to guarantee a reliable mechanical installation.

This construction technique, in combination with the absence of cables for power or sensors results in a very high immunity to electrical interference and very low levels of RF emission. The ShockLog® 298 may safely be used in close proximity to sensitive instruments or in difficult electromagnetic environments.

The ShockLog® 298 has been designed to meet IP67 (including connectors) and is capable of operating at temperatures between -40 and 85°C.

How to Use the ShockLog® 298

Control your ShockLog® device through a simple Windows®-based software program. The software allows for configuration of the ShockLog® 298, data extraction, and analysis. Once configured, mount the ShockLog® 298 to the equipment to be monitored. When the journey is complete, remove the ShockLog® and download the recorded information. The ShockLog® Report View provides users with an overview of the entire journey. ShockLog® 298 provides peak acceleration values for all three axes reported on a time basis as well a detailed impact curve. Additional environmental conditions can be monitored and displayed, if desired. (See Accessories and Related Products below for more information.) Users are able to zoom in for a closer view, or export data into programs such as Excel and MatLab for more detailed analysis. Please refer to the manual for full details.

Communications

The ShockLog® 298 has several mediums of communication. The primary method is via USB. The ShockLog® PC software automatically finds an attached unit so there is no need to identify which USB port is used.

When conditions do not dictate a fixed water tight link a standard cable can be used. An IP67 watertight USB connector is available when conditions warrant its use. The supplied watertight cap should be refitted after communications are complete. Should the cap be left off, the unit remains water tight but the exposed connections may become tarnished which may lead to poor communications.

For a quick and simple way of setting up, starting or stopping a unit in the field, an iButton interface is available. The iButton interface also supports the download of a 'one page report' giving a condensed view of the journey data gathered.

Optional RF Communication Interface

2.4GHz ZigBee radio link

Provides real-time data transfer for fixed applications and auto-download upon arrival for mobile applications. Must be specified at the time of order; cannot be retrofit.

Security

The ShockLog® 298 stores all data and status information in high performance FLASH memory. This memory requires no power to retain data. The instrument is configured by connecting to a PC and running the data analysis / setup software. During the configuration process the operator has the option of setting passwords in order to limit subsequent access to data.

If passwords have been enabled to restrict access to data, reset the unit or other functions, the user must supply those passwords before the software will communicate with the ShockLog®.

An area of the flash memory is reserved for the security log – this memory records the timing of such actions as resetting the clock or clearing out data and cannot be modified by the operator. It is intended that the security log last the operating life of the instrument and will only be cleared when the ShockLog® is recalibrated at the factory.

Software

The ShockLog® 298 software runs on a desktop or laptop PC using the Windows XP, Vista, Windows 7, or Windows 8 operating systems.

The software allows the operator to configure the ShockLog® 298 and to extract and examine data records from the instrument.

Reports may be viewed on screen and selected data exported to other applications. Six different reports are available: download, summary, events summary, event details, time slot, and log data.

Download:

This report presents a top-level view of a mission, providing the user with a single page report that can be printed or copied into another document. It contains a Time Slots graph, an Event Summary graph, and the most severe event as well as configuration information. The report start and end time can be adjusted to focus on any part of the mission.

Summary Report:

Data gathered at regular intervals is condensed into summary records. The period over which data is summarized can be set between 10 minutes and 24 hours according to the demands of the application. The summary records can be used to give an overview of a long period of data logging in a conventional spreadsheet format. A maximum of 1,024 summaries can be recorded in any one mission. The typical summary report parameters are date, time, number of warnings, number of alarms, max peak x, y, and z, gRMS x, y, and z, max/min temperature, and range.

Events Summary Report:

All the events are presented in a graphical or spreadsheet form. For each event the following parameters are available: date, time, range, temperature, max/min x/y/z, modulus. In addition the maximum modulus of all the events may be displayed graphically.

Event Details Report:

Detailed information for all of the recorded events is available in spreadsheet or graphical form. When the graphical form is used pan and zoom controls are available. The following parameters are available: sample time, sample number, max/min x, y, and z

Time Slot Report:

Data recorded in the timeslot memory can be displayed in graphical form. The following parameters can be available depending on setup and unit specification: date, time, max peak x, y, and z, min peak x, y, and z, gRMS x, y, and z, max ext1, ext2, min ext1, ext2, internal temperature, humidity, pressure, external temperature, Tilt & Roll, external accelerometer.

Security Log Report:

The security log data can be displayed in spreadsheet form. The following parameters are available: date and time of, data clearing operations or resets.

Product Selection

	SL298-A	SL298-H-A	SL298RF-A	SL298GPS-A	SL298TR-A	SL298GPS-TR-A	SL298RF-TR-A	SL298RF-H-A	SL298GPS-H-A	SL298TR-H-A	SL298GPS-TR-H-A	SL298RF-TR-H-A
RECORD / MEASURE												
Impact	X	X	X	X	X	X	X	X	X	X	X	X
Internal Temperature	X	X	X	X	X	X	X	X	X	X	X	X
gRMS	X	X	X	X	X	X	X	X	X	X	X	X
Velocity	X	X	X	X	X	X	X	X	X	X	X	X
External Temperature		X						X	X	X	X	X
Humidity		X						X	X	X	X	X
Tilt					X	X	X			X	X	X
Roll					X	X	X			X	X	X
GPS Coordinates				X		X			X		X	
COMMUNICATE VIA												
USB	X	X	X	X	X	X	X	X	X	X	X	X
iButton	X	X	X	X	X	X	X	X	X	X	X	X
RF Base Station			X				X	X				X

Best Practices for Mounting

Mount the ShockLog® close to the most sensitive part of the product being monitored. The ShockLog® should be mounted to a solid, rigid surface and as low as possible. When monitoring long shipments (>20 feet / 6 meters), it is best to mount a ShockLog® at both ends of the shipment.

For best results, it is recommended that the unit be mounted directly to the product being monitored using all four mounting bolts included with the ShockLog®, as shown in the figure below.

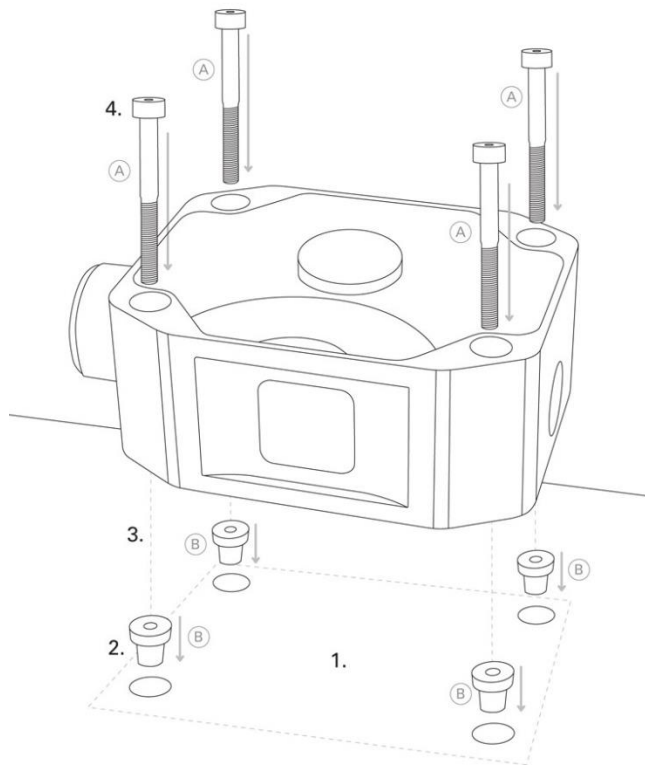

Kit contains:

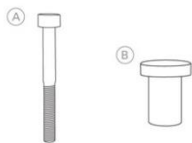

(B) 4 x M5x45 bolts

(C) 4 x black rubber anti-vibration isolation bushings

You will need:

- Electric drill with drill bit between 10.2mm and 10.3mm in diameter
- 5mm allen key

Instructions:

1. Drill 4 (four) Ø10.2mm-10.3mm holes in your product to a depth of at least 17mm. Alternatively a mounting plate with the four holes could be mounted to your product.
2. Insert the 4 isolation bushings in the 4 holes, narrow end first.
3. With the ShockLog facing up align bolts with anti-vibration bushings.
4. Push M5 bolts through the holes from front to back. Tighten bolts clockwise with the allen key. Begin with 2 bolts diagonally opposite each other for optimal grip.

ShockLog[®] 298 Technical Data

If it is not possible to mount the ShockLog[®] with mounting bolts, it is possible to use an aggressive adhesive or double-sided tape; however, it is important to remember that the ShockLog[®] should not be free to move inside the shipment.

Additionally, standard and magnetic mounting plates are available that have been predrilled for the four rubber bushings provided in the mounting kit. See the Drawings section for plate dimensions.

Avoid building special brackets to mount the ShockLog[®]. If a cover is required over the product being monitored, place the cover over the ShockLog[®], but do not attach the unit to the cover.

The ShockLog[®] assumes the axes indicated on the unit. Mount the ShockLog[®] either vertically or horizontally and note the orientation to assist with data analysis.

Drawings

ShockLog 298[®]

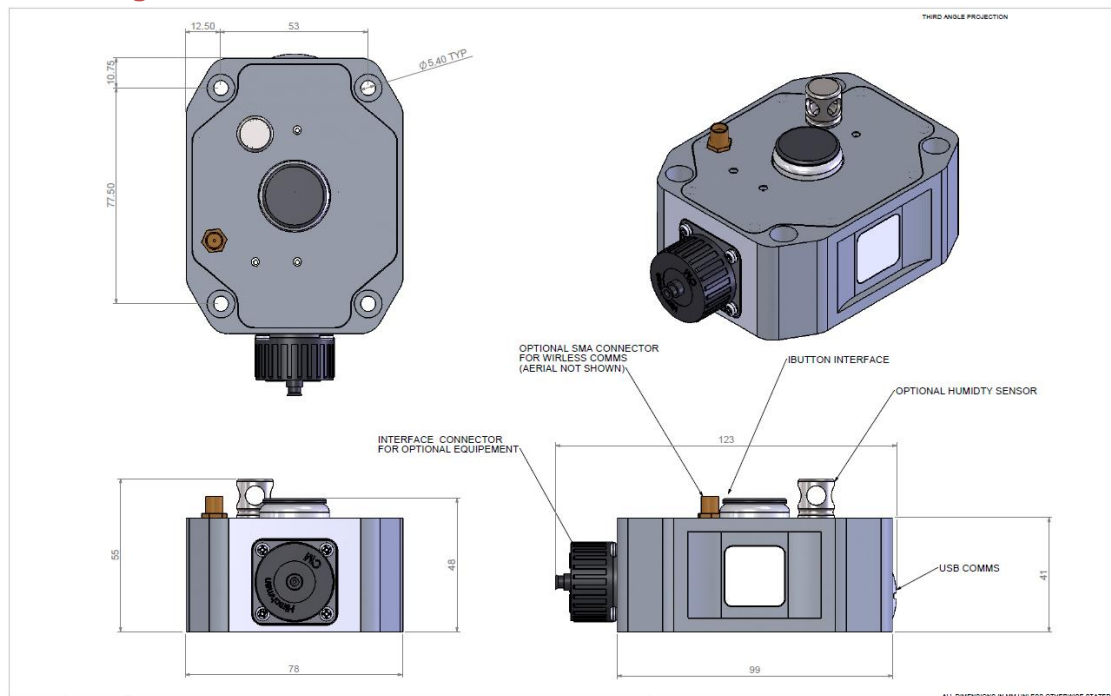

Standard Mounting Plate

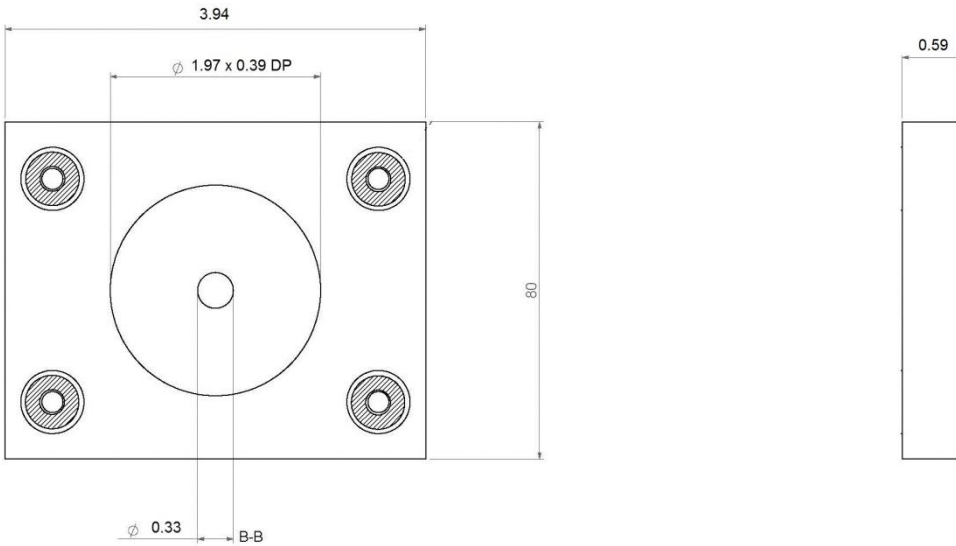

Note: Dimensions in inches

A mounting hole in the middle of the standard mounting plate attaches to the shipment. The mounting hole has been sized for an M8 bolt but can be drilled out to accept a larger bolt.

Magnetic Mounting Plate

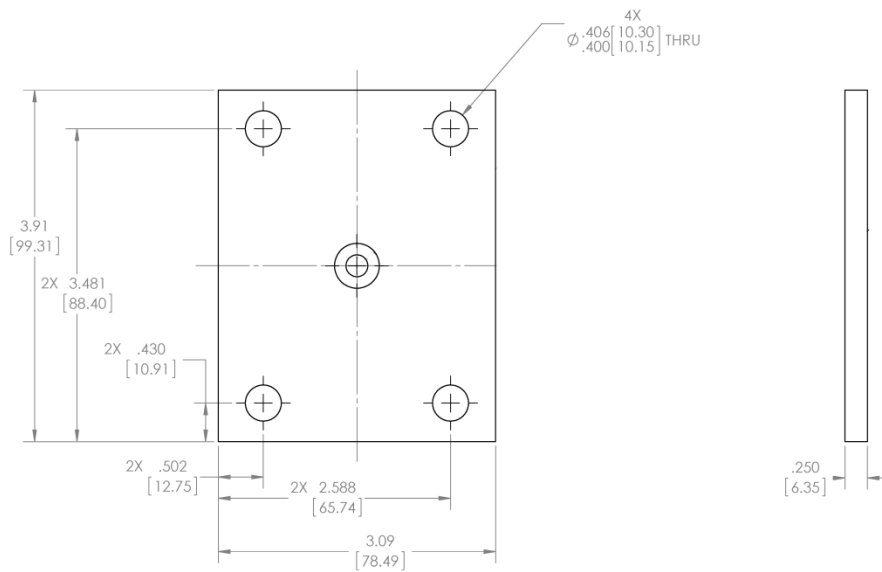

Note: Dimensions in inches

Accessories & Related Products

Batteries, a mounting kit and a companion label are included with each ShockLog® 298. New users of the ShockLog® 298 will be required to purchase a kit in order to get all the necessary accessories and software licenses to correctly operate the device. The kit contains the following items (CD containing software and manual; Quick Start User Manual; USB Communication Cable; iButton Set: start, stop, download, setup, and clock iButtons; USB Connection BUS and Cable; and 2 AA Lithium Batteries). Additional software licenses, iButtons, and cables can be ordered separately.

The following components can be ordered to extend the conditions monitored by the ShockLog®:

- Optional Humidity/Temperature Sensor (built-in)
- Optional Humidity/Pressure/Temperature Sensor (accessory)
- Optional Tilt & Roll Sensor (built-in)
- Optional GPS Coordinator Sensor (built-in)
- Optional GPS Tracking Unit (accessory)

Declaration of Conformity

This ShockLog® product is in compliance with the essential requirements and other relevant provisions of directives, ESTI EN 301 489, EN 61326, FCC Rules CFR47 Parts 15 and RTCA/DO160D. Copies of these Declarations of Conformity are available upon request.

Ordering Information

ShockLog® 298 units include batteries, mounting kit and companion label.

Part Number	Description
SL298-A	ShockLog® 298 Unit
SL298-H-A	ShockLog® 298 Unit w/ External Humidity & Temperature Sensor
SL298RF-A	ShockLog® 298 Unit w/ RF Module
SL298GPS-A	ShockLog® 298 Unit w/ GPS Module
SL298TR-A	ShockLog® 298 Unit w/ Tilt & Roll Sensor
SL298GPS-TR-A	ShockLog® 298 Unit w/ GPS Module and Tilt & Roll Sensor
SL298RF-TR-A	ShockLog® 298 Unit w/ RF Module and Tilt & Roll Sensor
SL298RF-H-A	ShockLog® 298 Unit w/ External Humidity & Temperature Sensor and RF Module
SL298GPS-H-A	ShockLog® 298 Unit w/ External Humidity & Temperature Sensor and GPS Module
SL298TR-H-A	ShockLog® 298 Unit w/ External Humidity & Temperature and Tilt & Roll Sensors
SL298GPS-TR-H-A	ShockLog® 298 Unit w/ External Humidity & Temperature and Tilt & Roll Sensors and GPS Module
SL298RF-TR-H-A	ShockLog® 298 Unit External Humidity & Temperature and Tilt & Roll Sensors and RF Module
SL 298RF-BS	ShockLog® 298 RF Base Station Required for ShockLog® units with RF Module installed
SL KIT 298-248-A	ShockLog® 298/248 Accessory Kit
RD298HPTX2	External Humidity, Pressure & Temperature Sensor (2 Bar/29 PSI)
RD298HPT	External Humidity, Pressure & Temperature Sensor (1 Bar/14.5 PSI)
40501K	eTrak Kit

Technical Support

If you are unsure of how to use or interpret the ShockLog® 298, please contact ShockWatch Technical Support at (800) 527-9497 or (214) 736-4580.

Warranty

If a product fails to conform to the specifications stated in this document, the product may be returned to ShockWatch at any time prior to the product's specified expiration date or, if no expiration date is specified, within one year from the date of shipment. ShockWatch shall either refund the purchase price (without interest), or repair and/or replace the product (or, in the case of services, re-perform such services) at no additional cost. The warranty is void if the defect has resulted from accident, misuse, abuse or misapplication. Any product which is identified as defective during the warranty period and is returned to ShockWatch with a Return Material Authorization (RMA) number (which must be obtained from ShockWatch prior to any return) within thirty (30) days after discovery of the defect with a written description of the defect will be replaced by ShockWatch.

Limitation of Liability

Seller makes no warranty, expressed or implied, except that the Products sold hereunder shall conform to Seller's written specifications for such Products as in effect and provided to Buyer by Seller at the time of sale of such Products to Buyer ("Seller's Specifications").

WARRANTY SET FORTH ABOVE IS EXCLUSIVE AND IN LIEU OF ANY AND ALL OTHER WARRANTIES, REPRESENTATIONS, AND COVENANTS, EXPRESS OR IMPLIED, STATUTORY, UNDER COMMON LAW OR OTHERWISE. EXCEPT AS PROVIDED IN THE SELLER'S TERMS & CONDITIONS, SELLER MAKES NO, AND EXPRESSLY DISCLAIMS, AND BUYER HEREBY EXPRESSLY WAIVES, IN EACH CASE TO THE MAXIMUM EXTENT PERMITTED BY APPLICABLE LAW, ANY AND ALL WARRANTIES, GUARANTEES, PROMISES, OR REPRESENTATIONS WITH RESPECT TO THE PRODUCTS, WHETHER WRITTEN, ORAL, EXPRESSED, OR IMPLIED, AND WHETHER IN FACT OR BY OPERATION OF LAW, STATUTORY, OR OTHERWISE, INCLUDING, WITHOUT LIMITATION, ANY IMPLIED WARRANTY OF MERCHANTABILITY OR SUITABILITY OR FITNESS FOR ANY PARTICULAR PURPOSE OR ANY WARRANTY OF NON-INFRINGEMENT (INCLUDING PATENT INFRINGEMENT, BOTH DIRECT AND INDIRECT, AND INCLUDING BOTH CONTRIBUTORY AND INDUCING PATENT INFRINGEMENT).

CONDITIONS, BUYER ASSUMES ALL RISK WHATSOEVER, AND SELLER (AND SELLER'S SHAREHOLDERS, DIRECTORS, MANAGERS, OFFICERS, EMPLOYEES, AND OTHER AFFILIATES (COLLECTIVELY, "SELLER'S AFFILIATES")) SHALL NOT BE LIABLE, FOR ANY LOSS, DAMAGE, OR LIABILITY INCURRED BY BUYER OR BY ANY USER OF ANY PRODUCTS ARISING OUT OF THE USE OF SUCH PRODUCTS, WHETHER SINGLY OR IN CONJUNCTION WITH ANY OTHER EQUIPMENT OR PROCESS, AND WHETHER DUE TO THE NEGLIGENCE OF SELLER OR ANY OTHER PERSON OR ENTITY. THE LIABILITY OF SELLER AND SELLER'S AFFILIATES FOR ANY FAILURE OF A PRODUCT TO CONFORM TO SELLER'S SPECIFICATIONS SHALL BE LIMITED EXCLUSIVELY TO, AT SELLER'S ELECTION, EITHER (1) REFUND OF THE PURCHASE PRICE PAID BY BUYER FOR SUCH PRODUCT (WITHOUT INTEREST) OR (2) REPAIR OR REPLACEMENT OF SUCH PRODUCT (OR, IN THE CASE OF SERVICES, REPERFORMANCE OF SUCH SERVICES). IN THE EVENT A COURT OF COMPETENT JURISDICTION SHOULD RULE THAT SELLER OR ANY OF SELLER'S AFFILIATES IS ANSWERABLE IN DAMAGES NOTWITHSTANDING THE LIMITATION OF LIABILITY SET FORTH HEREIN, THE AGGREGATE AMOUNT OF SUCH DAMAGES FOR WHICH SELLER AND SELLER'S AFFILIATES ARE LIABLE SHALL NOT EXCEED THE TOTAL OF ALL PAYMENTS MADE BY BUYER TO SELLER UNDER THE AGREEMENT WITH RESPECT TO THE RELEVANT PRODUCTS. SELLER AND SELLER'S AFFILIATES SHALL IN NO EVENT BE LIABLE TO BUYER OR ANY OTHER PERSON OR ENTITY FOR INDIRECT, SPECIAL, INCIDENTAL, CONSEQUENTIAL, PUNITIVE, OR EXEMPLARY DAMAGES, OR FOR DIMINUTION IN VALUE, LOST PROFITS, OR LOST BUSINESS OPPORTUNITY DAMAGES OF ANY NATURE, ARISING OUT OF OR RELATING IN ANY WAY TO THE PERFORMANCE UNDER OR BREACH OF THE AGREEMENT OR THE PURCHASE OR SALE OR USE OF THE PRODUCTS.

NOTWITHSTANDING ANYTHING TO THE CONTRARY CONTAINED HEREIN, BUYER EXPRESSLY ACKNOWLEDGES THAT SELLER HAS TESTED THE PRODUCTS ONLY AS SET FORTH IN THE SELLER'S SPECIFICATIONS AND NOT FOR USE WITH OR INCORPORATION INTO ANY PARTICULAR APPLICATION, AND BUYER ASSUMES AND BEARS ALL RISK AND RESPONSIBILITY OF DETERMINING THE SUITABILITY OF THE PRODUCTS FOR THE PURPOSE INTENDED BY BUYER OR BUYER'S CUSTOMER. BUYER SHALL NOT MAKE ANY REPRESENTATION TO ANY THIRD PARTY (1) REGARDING THE RELIABILITY OR ACCURACY OF THE PRODUCTS EXCEPT AS EXPRESSLY SET FORTH IN SELLER'S SPECIFICATIONS OR (2) TO THE EFFECT THAT SELLER HAS TESTED THE PRODUCTS FOR THE USE INTENDED BY BUYER OR SUCH THIRD PARTY.

BUYER SHALL INDEMNIFY, DEFEND, AND HOLD SELLER AND SELLER'S AFFILIATES HARMLESS FROM AND AGAINST ANY AND ALL CLAIMS, DEMANDS, LOSSES, DAMAGES, RESPONSIBILITIES, OBLIGATIONS, LIABILITIES, COSTS AND EXPENSES (INCLUDING WITHOUT LIMITATION ATTORNEY FEES, COURT COSTS, COSTS OF ALTERNATIVE DISPUTE RESOLUTION PROCEEDINGS, AND COSTS OF SETTLEMENT) BROUGHT BY ANY PARTY REGARDING PRODUCTS SOLD BY SELLER AND INCORPORATED INTO OTHER ITEMS MANUFACTURED OR SOLD BY BUYER, INCLUDING BUT NOT LIMITED TO ANY CLAIM OF DIRECT OR INDIRECT PATENT INFRINGEMENT.